

Introduction

At the 2006 PMI COS conference a paper entitled “Scheduling 101: A “Behind – the – Scenes” Look at Basic Schedule Calculation was presented by Scott W Cramer, James L Jenkins, and Joseph J Orczyk¹. In the paper they present a “Comparison between AON and PDM” (page 8), in which they make a case for using Precedence Diagram Method for overlapping tasks using three basic construction tasks. They then demonstrate the process of overlapping the three PDM tasks and how the critical path computations are calculated.

In their example of using Start to Start and Finish to Finish links to simplify the network, they clearly demonstrate a major flaw in the PDM calculations. This flaw is known to many planners and schedulers as “Lag Drag”, where the Earliest Start of the task is dragged to the right, because the software used subtracts the duration from the Earliest Finish Date, Jenkins, Kramer and Orczyk state “.... the ES value is then calculated by $EF \text{ minus } Duration$

Lag Drag is where the Earliest Start of a Task is dragged to the right due to a longer task progressively feeding a shorter task and SS and FF links have been used to define this overlapped work. This phenomena is due to the way PDM computations are calculated, i.e. $ES = EF - duration$ rather than the normal ES calculation as defined by Henderson 1998² which says that “The earliest start time for each activity (i,j) is equal to the earliest possible time for the preceding event E(i):” in other words

$$ES = PEE$$

Using an arrow diagram to define overlapping (progressive feed) activities does not suffer from the lag drag problem provided the software programme follows the ladder convention

This paper will define the term Progressive Feed and the definition of a Ladder and demonstrate well as the appropriate calculations to prevent lag drag

Progressive Feed Activities

The use of series and parallel activities is satisfactory for most project purposes. In some cases however, work elements in an activity are progressively released to the next activity thus causing them to be overlapped during their execution. The need to use overlapping is very common in construction, especially where the project is a multi story building.

The term “progressive feed” is associated with these activities in a related chain of *interdependent* activities, and it implies the release of information and / or work elements which constitute *part* of the whole activity, to a succeeding activity, thus establishing for the latter in its earliest feasible start date. It also assumes an agreed rate of work flow of subsequent elements in the chain to permit operations to be more or less continuous in each activity.

To represent progressive feed accurately in a network, each element must be treated separately throughout the chain of activities. It is also necessary to include dummies to portray interval times which occur between elements. The network diagram below in Figure 1, deals with *three* elements in a chain of *four* elements in Arrow Diagram Method or Activity on Node as the method is also known.

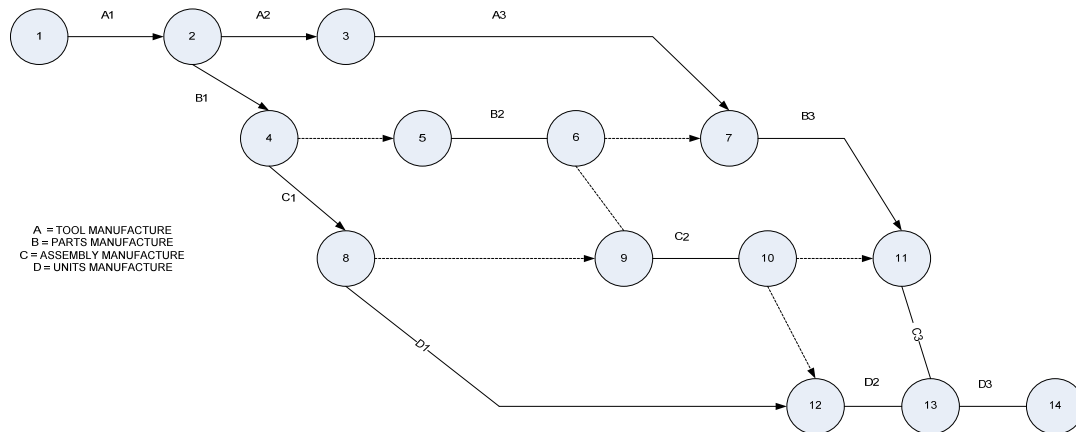

Figure 1

It requires nineteen activities of which seven must be dummies in order to depict the true relationship between the elements in the chain. For instance, activity 5 – 6, element B2, must be preceded by a dummy from 4 – 5, and one between 3 – 5, for B, can only be commenced after the completion of A2, by comparison with B1, it is essential to insert dummy 4 -5. The start of activity 5 – 6 will now be conditioned either by event 3 or event 4, whichever is the later.

Except perhaps for production control applications, this degree of detail is rarely required, hence the need to find a compromise solution to convey the idea of progression and provide some degree of control over start and finish elements.

The Ladder Convention

The term “Ladder” (originally invented by the British Computer company International Computers and Tabulators in 1964)³, is both descriptive of the configuration and indicative of progressive feed. The example figure two and three are used to simplify explanations.

1. The horizontal ‘rungs’ of the ladder, A – B, C – D, E – F and G – H represent the main activities where *work is to be performed using resources*.
2. The side struts commonly referred to as Lead and Lag activities, i.e. LEAD = A – C, C – E, E – G and LAG = B – D, D – F, F – H, are purely linking lines in the chain, although they can be regarded as dummies having a time value, they do not use resource; the resources are accounted for in the main

3. It is often desirable for visual purposes to distinguish between start and finish events in a ladder section, and a convenient symbol to use for finish events is a square, as in Figure two and three below. *Note: Since the advent of PC based software the square is no longer used.*
4. All estimated times must be based upon Work Time assuming contiguous working and not elapsed time. As already demonstrated in the diagram above it is not possible to estimate elapsed times, i.e. work time plus interval times, without relating elements to a time scale.
5. The concept of Work Time is extremely important and must be observed, since Micro Planner X-Pert for Windows uses special logic for Ladder computations. Estimates for each activity may be made in isolation disregarding all extraneous restraints imposed by the other activities. The software program will allow for interaction between activities and calculate the required duration.
6. All the main activities should be estimated before considering the relevant Lead and Lag times. These latter values must inevitably be a proportion of the main activity values. For example, activity A – B,.. Make Tools (A1, A2, A3) = 5 weeks Work Time. The associated Lead activity A – C is an expression of the time required to make the “First Tools”, i.e. one week, which is effectively establishes the earliest feasible start date for the following activity “Make Parts”. The responsibility for estimating Lead times therefore, devolves upon the Issuing source.
7. Conversely, Lag activities are an expression of the amount of work to be done by a Receiving department after release of the Last elements from a preceding activity. For example, activity B – D..is “Make Last Parts” = 2 weeks, the time required to manufacture the Last parts after receipt of Last tools.
8. To avoid any possible misrepresentation of the reports it is advisable to use the words First and Last respectively for Lead and Lag activities, for example Make First Tools and Make Last Parts.
9. The diagram (b) below has been drawn to a time scale to illustrate the relationship between elements in a ladder chain. In the example the *critical* activities are: A – C Make First Tools (A1), C – D Make All Parts, D – F Make Last Units (D3). The hatched portions represent those elements which are indeed critical.
10. The Float time shown for activities A – B, E – F, and G – H are a measure of the leeway permissible in those activities, but they do not necessarily reflect the precise moment of occurrence. In activity A – B element A3 can indeed be delayed two weeks without affecting the end date for the chain of activities. Element 2 however, could only be delayed one week otherwise it would delay the start of B2 in the wholly Critical activity. On the other hand, the float times shown for activities E – F and G – H must occur between C1 – C2 and D1 – D2 respectively.
11. All ladder activities in Micro Planner X-Pert for Windows / Mac are designated as such, as are the Lead and Lag activities

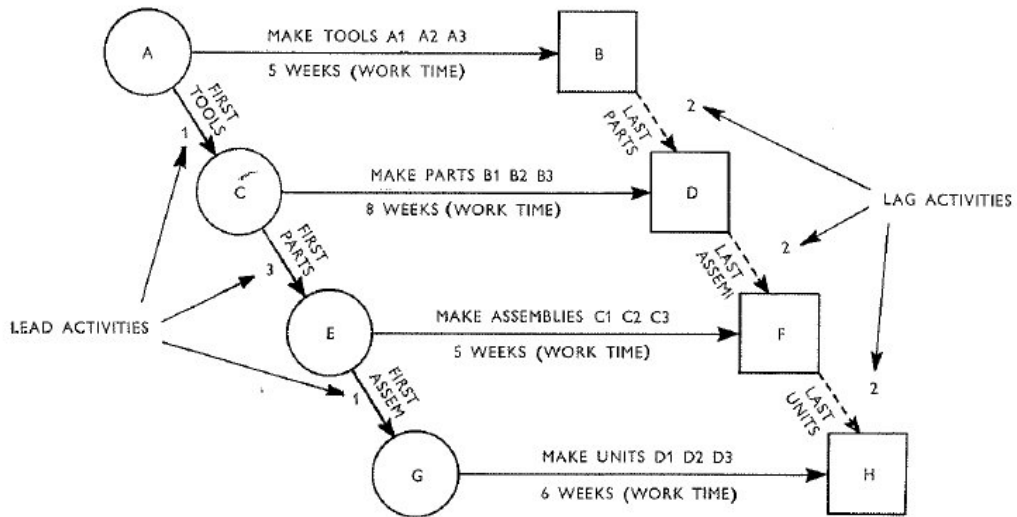

Figure 2

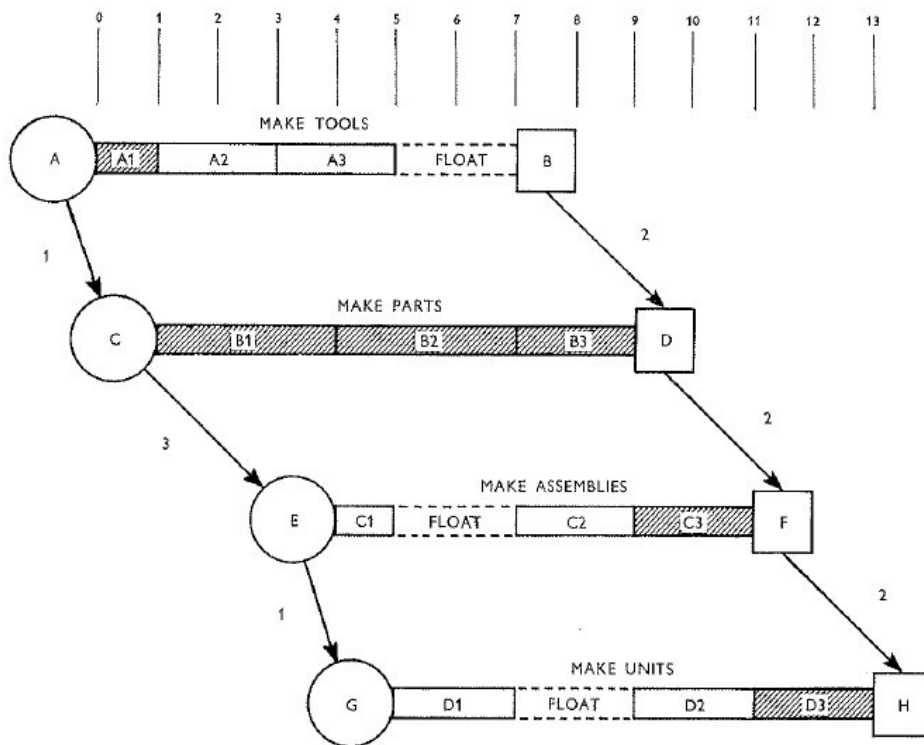

Figure 3

The Basic Element of a Ladder

The absolute basic elements of a ladder consists of three parts, the activity, in this case “Make Parts” the lead activity “Make First Parts” and the lag activity “Make Last Parts”. This shown in figure four below

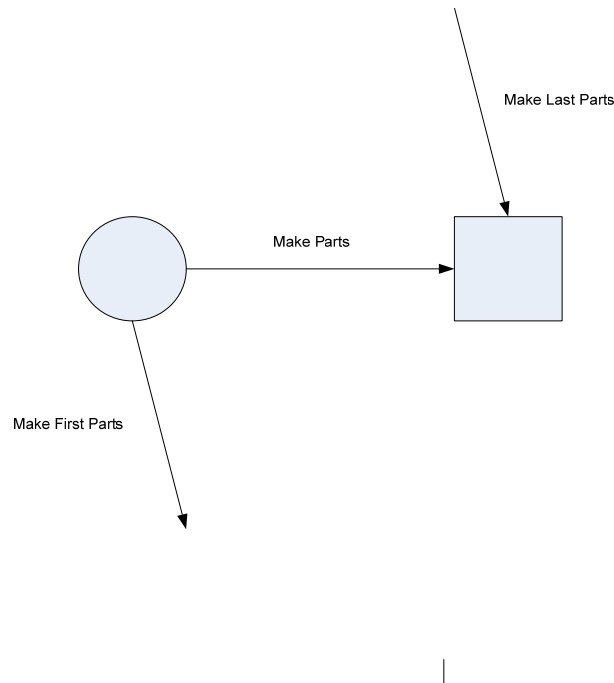

Figure 4

Calculating Critical Path Networks in ADM format

Paraphrasing Henderson 1998² for the definition of the Earliest Preceding Event time

The *earliest event time algorithm* computes the earliest possible time for the Preceding Event which is also known as the “i node”, $PEE(i)$, at which each event, i , in the network can occur. Earliest event times are computed as the maximum of the earliest start times plus activity durations for each of the activities immediately preceding an event. The earliest start time for each activity (i,j) is equal to the earliest possible time for the preceding event $PEE(i)$ this is known as the forward pass.

The forward pass calculations are thus obtained from the formula: $ES_j \equiv \max(ES_i + D_{ij})$ for all defined (i, j) activities where $ES_i \equiv 0$. Thus, in order to compute ES_j for event j , ES_i for the tail events of all the incoming activities (i,j) must be computed first.

$$ES(i,j) = PEE(i)$$

In figure five below all the arrow diagram elements which need to be calculated are indicated

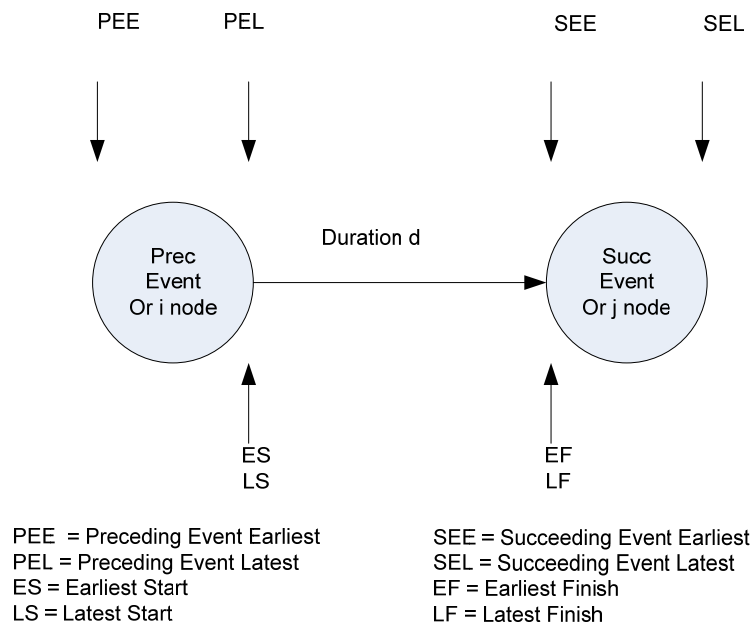

Figure 5

The calculations which are normally made are shown below for example Earliest Start Schedule time (ESS) is the earliest that an activity may start.

Earliest Start

(ES) is the earliest that an activity may start, based on all previous Management Date Constraints.

$$ES = \text{Max} (EES, PEE)$$

Earliest Finish

(EF) is the earliest an activity may finish.

$$EF = ES + A$$

$$\text{Or } EF = SEE$$

(for activities designated Ladder)

Latest Finish Schedule

Time (LFS) is the latest that an activity may finish.

Latest Finish

(LF) is the latest that an activity may finish, based on all Subsequent Management Date Constraints

$$LF = \text{Min} (LFS, SEL)$$

$$\text{Or } LS = PEL$$

(for activities designation Ladder)

Calculating a ladder within a network

A small example in how the calculations are carried is demonstrated using the example network below in figure six

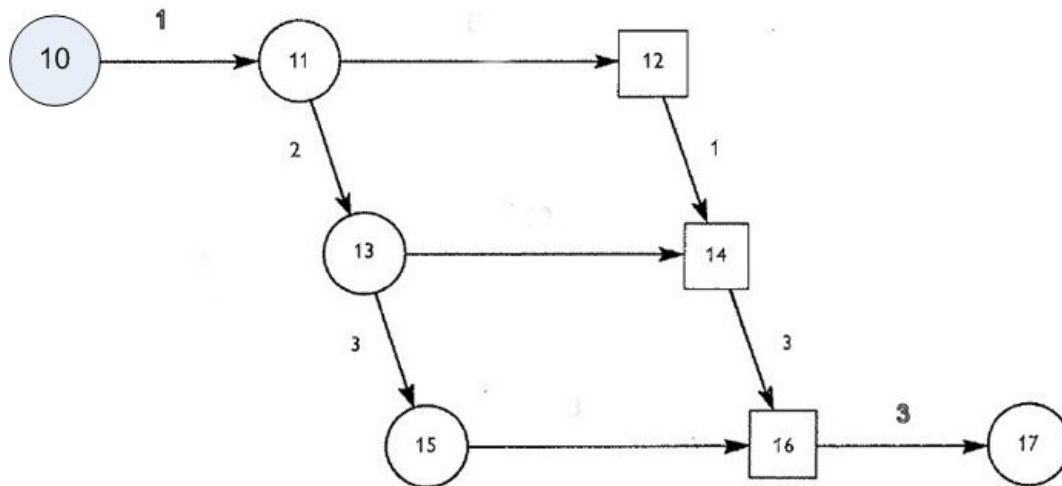

Figure 6

Forward Pass Computations

Step One: Set the earliest start and the earliest finish of activity 10 – 11 to zero:
 $(ES(0) = EF(0) = 0)$

Step Two: build a table as follows and apply the usual calculations, noting the ladder activity

Preceding Event	Succeeding Event	Activity Type	Duration	Earliest Start	Earliest Finish	
10	11	Activity	1	0	1	
11	12	Ladder	15	1	16	
11	13	Lead	1	1	2	
12	14	Lag	1	16	17	
13	14	Ladder	9	2	17	Note For Ladder EF = SEE
13	15	Lead	3	2	5	
14	16	Lag	3	17	20	
15	16	Ladder	8	5	20	Note For Ladder EF = SEE
16	17	Activity	3	20	23	

The duration for ladder activity remains the same, even though the elapsed time has increased. Note: Activity 13 – 14 duration is 9, but the elapsed time is 15 and for 15 – 16 the duration is 8, but the elapsed duration is 15. See diagram (b) for how float is induced into the ladder rung

Progressive Feed in PDM Format

Taking the arrow diagram in figure six and producing it in PDM format, produces the network below, figure seven

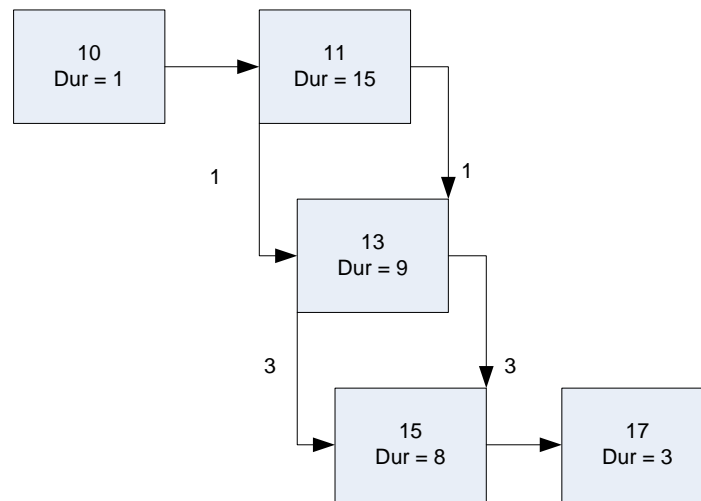

Figure 7

Forward Pass Computations

Calculating the forward pass manually using the traditional computational method gives the earliest start and finish dates shown in the table below

Task Id		Link Type	Duration	Earliest Start	Earliest Finish	
10		Task	1	0	1	
10	11	FS	0	1	1	
11		Task	15	1	16	
11	13	SS	1	2	17	
11	13	FF	1	16	17	
13		Task	9	2	17	Note EF = SEE
13	15	SS	3	2	5	
13	15	FF	3	17	20	
15		Task	8	5	20	Note EF = SEE
15	17	FS	0	20	20	
17			3	20	23	

The PDM network was processed using Micro Planner X-Pert for Windows and the results are shown in figure eight below and as can be seen are the same as the manual computations.

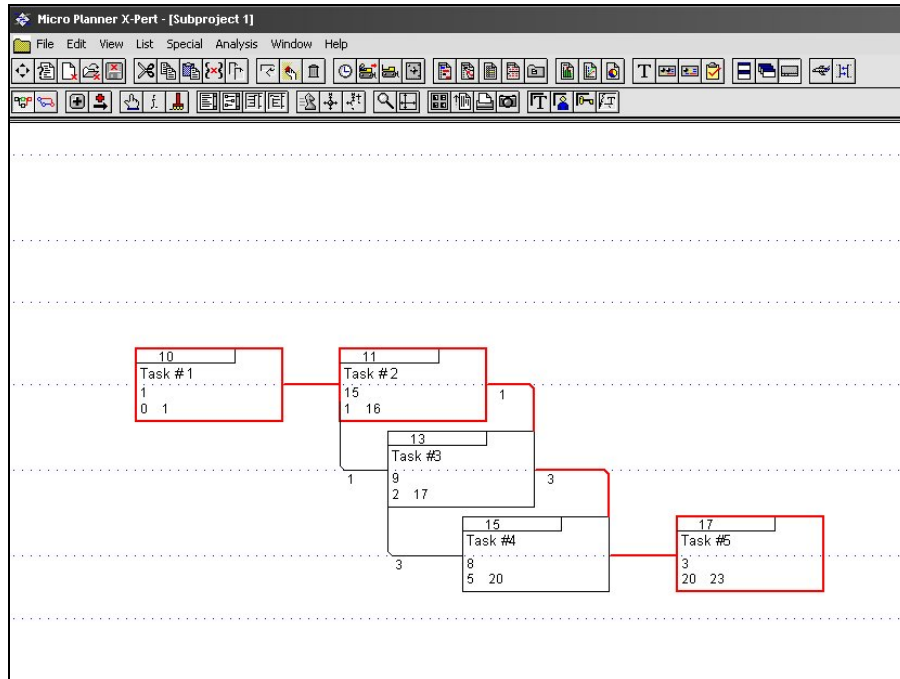

Figure 8

As can be seen task 13 has an Earliest Start date of 2 and an Earliest Finish date of 17, the float on the task will be 6.

Using the example Scott W Cramer, James L Jenkins, and Joseph J Orczyk shown in their paper below in figure nine and their results in figure ten, it can be seen that

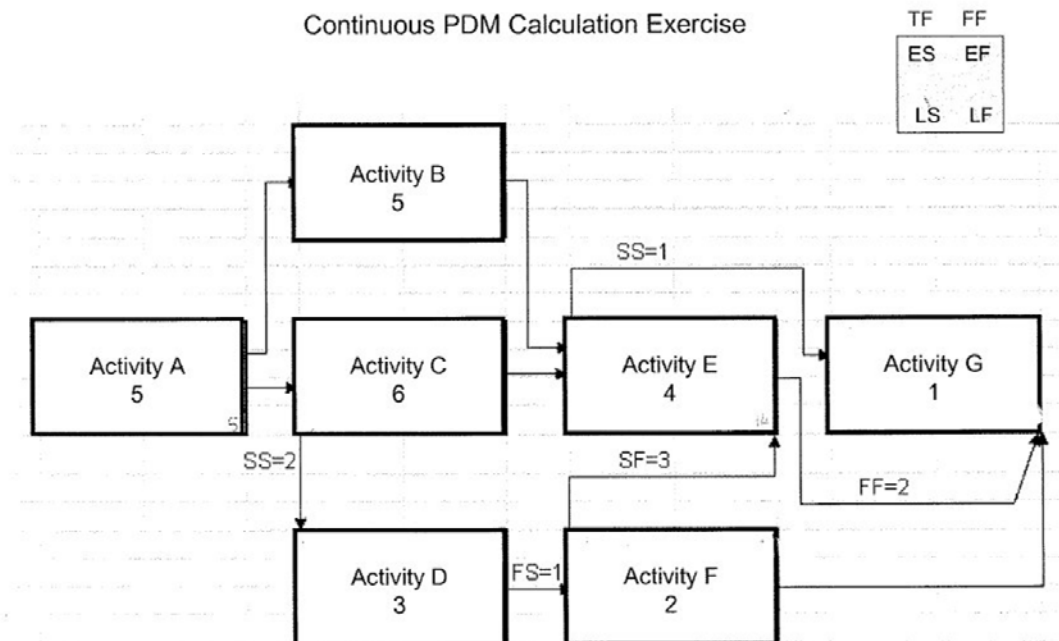

Figure 9

As can be seen Activity G has an Earliest Start of 16, this is due to the fact that the Earliest Start date has been calculated as the Earliest Finish minus the duration, i.e. $17 - 1 = 16$.

According to the ICL ladder technique the date should be 12, that is Earliest Start date of Activity E i.e., 11 plus the duration equals 12.

It is interesting to note that the Latest Finish of Activity is shown as 14, I would expected that it should be 17, that is Latest Finish Date of Activity G is 17

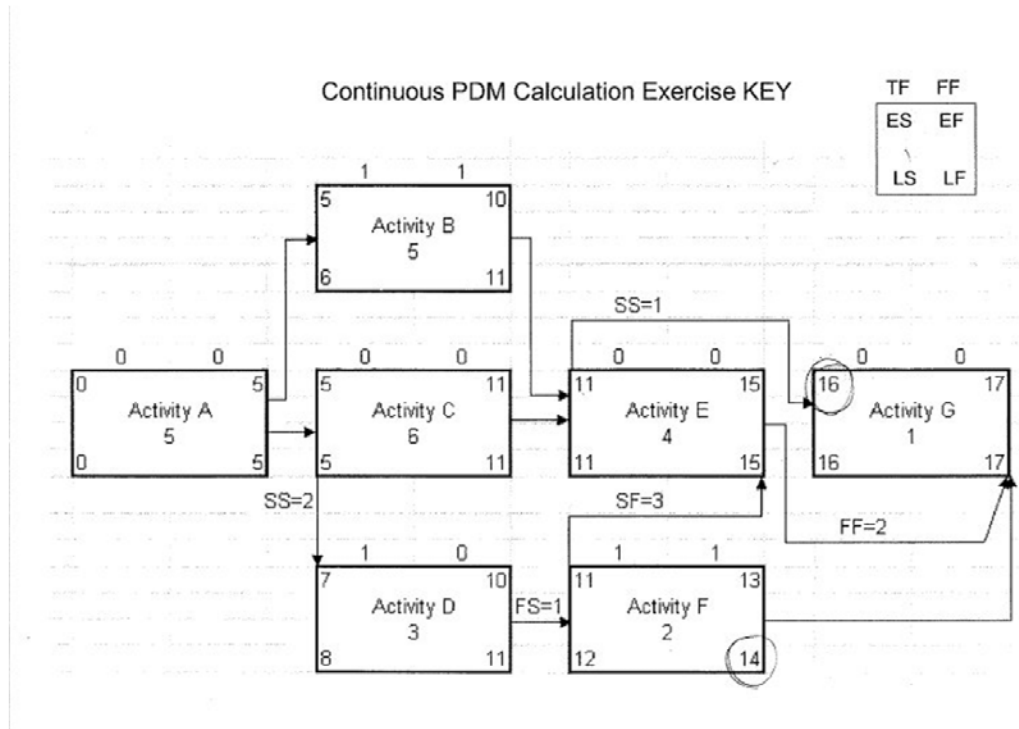

Figure 10

The network in Figure ten was processed using Micro Planner and the results can be seen in

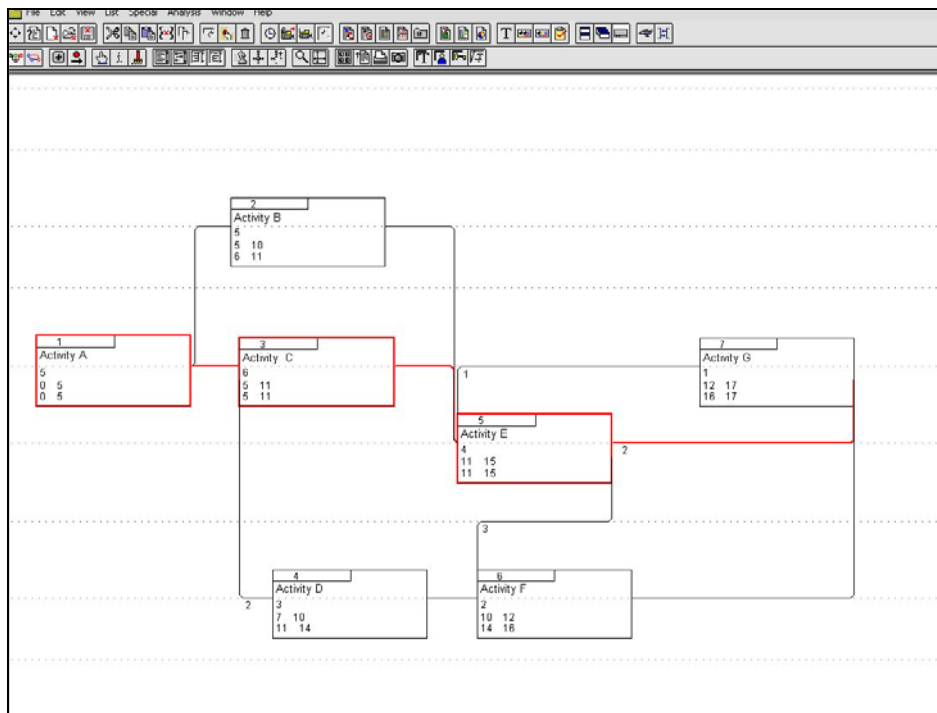

Figure 11

References

1. “Scheduling 101: A “Behind – the – Scenes” Look at Basic Schedule Calculation by Scott W Cramer, James L Jenkins, and Joseph J Orczyk¹.
2. Project Management for Construction **Fundamental Concepts for Owners, Engineers, Architects and Builders** by Chris Hendrickson, Department of Civil and Environmental Engineering, Carnegie Mellon University, Pittsburgh, PA 15213 Copyright C. Hendrickson 1998
3. ICT 1900 Pert Manual TL4133 1969, published by International Computers & Tabulators